

Art. TA 5160

Adattatore da tavolo con cavo di collegamento a 20 conduttori per monitori **PT5160**, **PT5160W** e **PT5160W-LCD**.

*Table adapter with 20 wire connection cable for monitors **PT5160**, **PT5160W** and **PT5160W-LCD**.*

Adaptateur, avec câble souple à 20 conducteurs et platine de raccordement, pour montage sur table des moniteurs **PT5160**, **PT5160W** et **PT5160W-LCD**.

*Adaptator de mesa con cable de 20 conductores para los monitores **PT5160**, **PT5160W** y **PT5160W-LCD**.*

Adaptator de mesa com cabos de ligação a 20 condutores para videoporteiros **PT5160**, **PT5160W** e **PT5160W-LCD**.

*Tischadapter mit 20 adriger Verbindungskabel für Bildschirmgeräte **PT5160**, **PT5160W** und **PT5160W-LCD**.*

Istruzioni di montaggio
Mounting instructions
Mode d'emploi
Instrucciones para el montaje
Instruções de montagem
Montageanleitung

Effettuare i collegamenti del cavo alla morsettiera dell'adattatore da tavolo rispettando la numerazione / colore della tabella allegata.

Make the connection of the cable to the terminals of the table adapter following the correspondence between the conductores color and the terminals number listed in the enclosed table.

Raccorder le câble souple sur le bornier en respectant le code de couleurs du tableau ci-contre.

Efectuar las conexiones del cable a los terminales del adaptador de mesa, respetando la numeración/color de la tabla adjunta.

Efectuar as ligações do cabo ao terminal de bornes do adaptador de mesa, respeitando a numeração/cor da tabela em anexo.

Die Adern nach Numerierung/Farbe (siehe beiliegende Tabelle) an den Tischadapter anschließen.

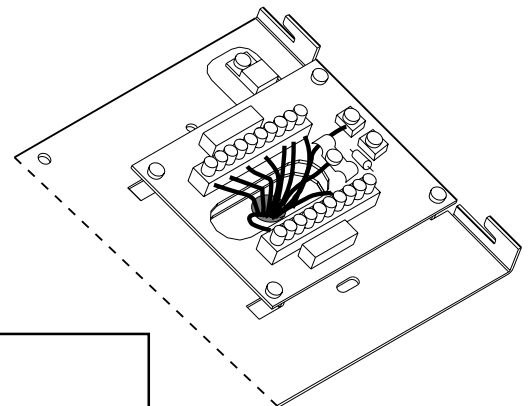

Corrispondenza del numero del morsetto con il colore del conduttore
Correspondence between terminals number and conductors color
Couleurs des fils et bornes correspondantes (à respecter)
Correspondencia del número del terminal con el color del conductor
Correspondência do número do borne com a cor do condutor
Klemmennummer gemäß Farbe der Leitung

Morsetti Terminals Bornes Terminales Terminais Klemmen	Colore dei conduttori	Conductors color	Couleur des conducteurs	Color de los conductores	Cor dos fios	Adern Farbe
1	bianco	white	blanc	blanco	branco	weiß
2	rosso	red	rouge	rojo	vermelho	rot
3	nero	black	noir	negro	preto	schwarz
4	giallo	yellow	jaune	amarillo	amarelo	gelb
8	rosso-verde	red-green	rouge-vert	rojo-verde	vermelho-verde	rot-grün
9	blu	blue	bleu	azul	azul marinho	blau
10	arancio	orange	orange	naranja	laranja	orange
11	verde	green	vert	verde	verde	grün
12	rosso-nero	red-black	rouge-noir	rojo-negro	vermelho-preto	rot-schwarz
13	giallo-verde	yellow-green	jaune-vert	amarillo-verde	amarelo-verde	gelb-grün
14	marrone	brown	brun	marrón	marrom	braun
X1	grigio	grey	gris	gris	cinza	grau
X2	celeste	light-blue	bleu-ciel	celeste	azul claro	hellblau
P1	viola	violet	violet	violeta	violeta	lila
P2	giallo-rosso	red-yellow	rouge-jaune	rojo-amarillo	vermelho-amarelo	rot-gelb
P3	rosso-blu	red-blue	rouge-bleu	rojo-azul	vermelho-azul	rot-blau
P4	verde-arancio	orange-green	orange-vert	naranja-verde	laranja-verde	orange-grün
P5	blu-arancio	orange-blue	orange-bleu	naranja-azul	laranja-azul	orange-blau
P6 - V	viola-arancio	orange-violet	orange-violet	naranja-violeta	laranja-viola	orange-lila
1C - 2C	giallo-nero	yellow-black	jaune-noir	amarillo-negro	amarelo-preto	gelb-schwarz



