



- I** STAFFA DI FISSAGGIO PER VIDEOCITOFONI KM8100, KM8600 E KM8800
- GB** WALL BRACKET FOR KM8100, KM8600 AND KM8800 VIDEOINTERCOMS
- F** SUPPORT DE FIXATION POUR VIDEOPHONES KM8100, KM8600 ET KM8800
- E** SOPORTE DE FIJACION PARA MONITORES KM8100, KM8600 Y KM8800
- P** SUPORTE DE FIXAÇÃO PARA VIDEO-PORTEIROS KM8100, KM8600 E KM8800
- D** BEFESTIGUNGSBÜGEL FÜR VIDEOSPRECHGERÄTE KM8100, KM8600 UND KM8800

FARFISA
INTERCOMS

MI 2279/2

Fissaggio a parete della staffa per il montaggio dei videocitofoni KM8100 e KM8800
 Fixing to wall of the bracket for the assemblage of the videointercoms KM8100 and KM8800
 Fixation murale de le support pour le montage des vidéophones KM8100 et KM8800
 Fijación a pared del soporte por el montaje de monitores KM8100 y KM8800
 Fixação a parede do suporte para a montagem dos video-porteiros KM8100 e KM8800
 Befestigung zu Wand vom Bügel für die Montage des Monitors KM8100 und KM8800

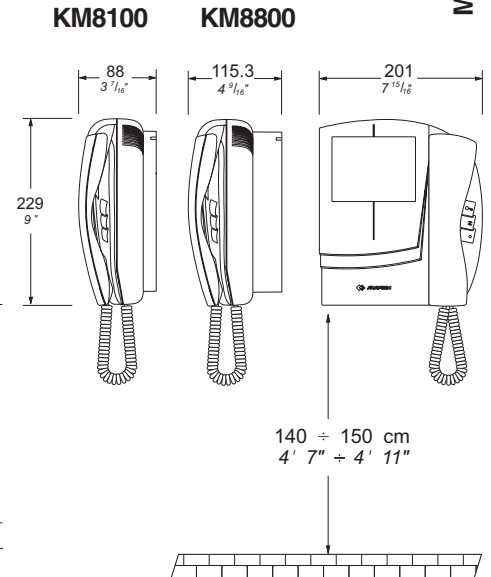
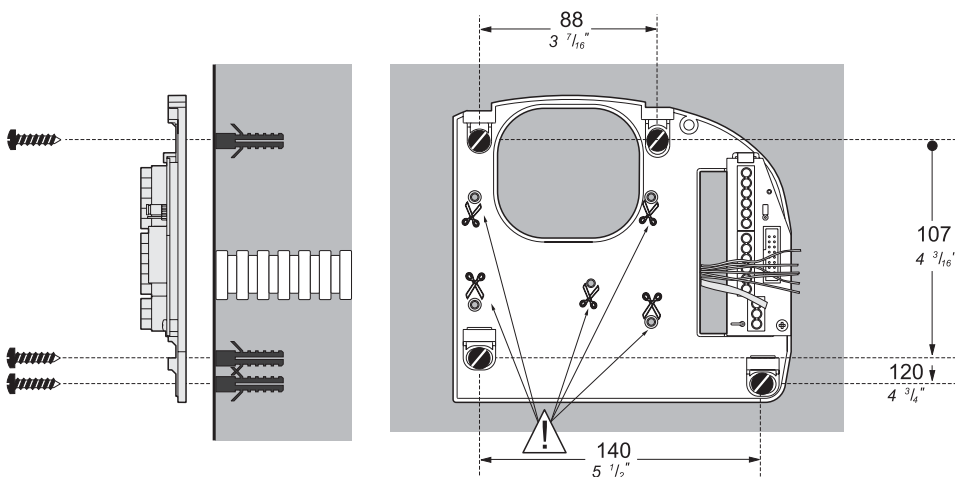

Fissaggio a parete (e su scatola da incasso 8083) della staffa per il montaggio del videocitofono KM8600
 Fixing to wall (and on back box 8083) of the bracket for the assemblage of the videointercom KM8600
 Fixation murale, et sur boîte d'encastrement 8083, de le support pour le montage du vidéophone KM8600
 Fijación a pared, y sobre la caja de empotrar 8083, del soporte por el montaje del monitor KM8600
 Fixação a parede (e em caixa de encastrar 8083) do suporte para a montagem do video-porteiro KM8600
 Befestigung zu Wand, und auf Unterputzgehäuse 8083, vom Bügel für die Montage des Monitors KM8600

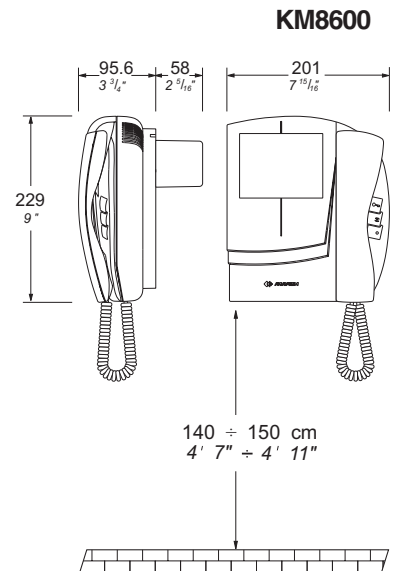
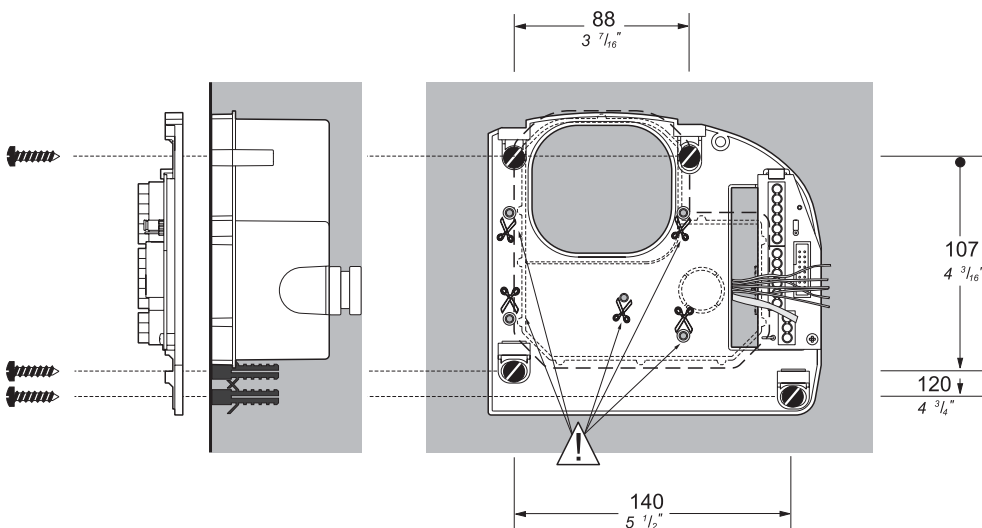

La ACI Farfisa Intercoms si riserva il diritto di modificare in qualsiasi momento i prodotti qui illustrati.
 ACI Farfisa Intercoms reserves the right to modify the products illustrated at any time.
 La ACI Farfisa Intercoms se réserve le droit de modifier à tous moments les produits illustrés.
 ACI Farfisa Intercoms se reserva el derecho de modificar todos los productos aquí ilustrados.
 Änderungen vorbehalten.















Smaltire il dispositivo secondo quanto prescritto dalle norme per la tutela dell'ambiente.
 Dispose of the device in accordance with environmental regulations.
 Écouler le dispositif selon tout ce qu'a été prescrit par les règles pour la tutelle du milieu.
 Eliminar el aparato según cuánto prescrito por las normas por la tutela del entorno.
 Disponha do dispositivo conforme regulamentos ambientais.
 Werden Sie das Gerät in Übereinstimmung mit Umweltregulierungen los.

Solo/only/solo/so/ seulement/nur

KM8600

KM8800

ACI srl Farfisa Intercoms
 Via E. Vanoni, 3 • 60027 Osimo (AN) • Italy
 Tel: +39 071 7202038 (r.a.) • Fax: +39 071 7202037
 e-mail: info@acifarfisa.it • www.acifarfisa.it

Morsetti Bornes Terminals Terminales Terminais Klemmen	Caratteristiche Description Caractéristiques	Description Descrição Beschreibung
H	Ingresso tensione positiva (18÷24Vcc) Power supply input (18÷24Vdc) Entrée tension positive (18÷24Vcc)	Entrada tensión positiva (18÷24Vcc) Entrada tensão positiva (18÷24Vcc) Eingang positive Spannung (18 bis 24Vdc)
F	Massa generale / General ground / Masse general	Masa general / Massa geral / Allgemeine Masse
9M	Ingresso soneria elettronica per chiamate da esterno con abilitazione monitor Electronic bell input for calls from external stations with enabled monitor Entrée sonnerie électronique pour appel depuis l'externe avec activation de l'écran	Entrada timbre electrónico para llamadas del exterior con habilitación del monitor Entrada som electrónico para chamadas do exterior com habilitação do monitor Eingang Elektronikruf für Außenrufe mit Monitoraktivierung
3	Massa fonica / Audio ground / Masse phonique	Masa fónica / Massa fónica / Sprechleitungsmasse
2	Fonia dall'esterno (altoparlante) Audio from external (speaker) Phonie depuis l'extérieur (haut-parleur)	Sonido del exterior (altavoz) Fonia do exterior (altifalante) Sprechverbindung von Türstation (Lautsprecher)
1	Fonia verso l'esterno (microfono) Audio to external (microphone) Phonie vers l'extérieur (microphone)	Sonido hacia el exterior (micrófono) Fonia em direcção ao exterior (microfone) Sprechverbindung zur Türstation (Mikrofon)
4	Accensione di controllo (pulsante ) Control switch-ON (button ) Allumage de contrôle (bouton-poussoir )	Autoencendido de control (pulsador ) Acensão de controle (botão ) Taste Kontrolleinschaltung 
5	Apertura serratura elettrica (pulsante ) Electric lock release (button ) Ouverture serrure électrique (bouton-poussoir )	Apertura cerradura eléctrica (pulsador ) Abertura fechadura eléctrica (botão ) Elektro-Türschloßöffnung 
8	Uscita tensione +12V +12V output Sortie tension positive +12V	Salida tensión positiva +12V Saída tensão positiva +12V Ausgang positive spannung +12V
P PC	Pulsante di servizio ● (max 0,3A) Service button ● (max 0,3A) Bouton-poussoir de service ● (0,3A max)	Pulsador de servicio ● (máx 0,3A) Botão de serviço ● (máx 0,3A) Funktionstaste ● (max. 0,3A)
9R	Ingresso soneria elettronica per chiamate intercomunicanti o di piano Electronic bell input for intercom or floor calls Entrée sonnerie électronique pour appels intercommunicants ou de palier	Entrada timbre electrónico para llamadas intercomunicantes o de piso Entrada som electrónico para chamadas intercomunicantes ou de patamar Eingang Elektronikruf für Gegensprechrufe oder Etagenrufe
V	Ingresso-uscita segnale video (cavo coassiale) Video signal input-output (coaxial cable) Entrée-sortie signal vidéo (câble coaxial)	Entrada-salida señal vídeo (cable coaxial) Entrada-saída sinal vídeo (cabo coaxial) Videosignaleingang / -ausgang (Koaxialkabel)
M	Massa video (schermo coassiale) Video ground (coaxial shield) Masse vidéo (blindage coaxial)	Masa vídeo (pantalla coaxial) Massa vídeo (tela coaxial) Video-Erdung (Koaxialkabel)

- **Selezione del segreto fonico o servizio intercomunicante**
- **Selection of audio privacy or intercommunicating service**
- **Sélection du secret phonique ou du service intercommunicant**
- **Selección del secreto fónico o servicio intercomunicante**
- **Seleção do segredo fónico ou do serviço de intercomunicação**
- **Selektion von Sprechheimnissen oder Gegensprechfunktion**

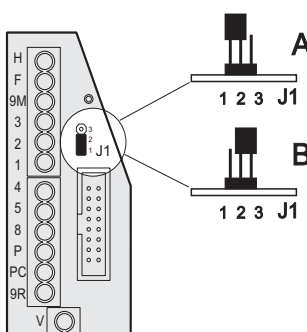

- A** = Videocitofono senza segreto fonico
Videointercom without private conversation
Vidéophone sans secret de conversation
Monitor sin secreto fónico
Video-porteiro sem segredo fónico
Monitor ohne Mithörsperre
- B** = Videocitofono con segreto fonico
Videointercom with private conversation
Vidéophone avec secret de conversation
Monitor con secreto fónico
Video-porteiro com segredo fónico
Monitor mit Mithörsperre

