

IT KIT CITOFONICO GSM CON TASTIERA PER CONTROLLO ACCESSI

EN GSM INTERCOM KIT WITH KEYPAD FOR ACCESS CONTROL

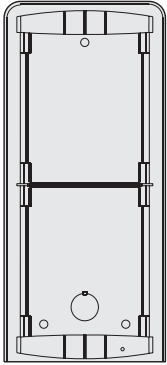

PL92
Tettuccio antipioggia e telai portamoduli
Rain shelter with module frames

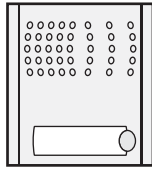

PL11G
Posto esterno citofonico con tecnologia GSM
GSM intercom door station

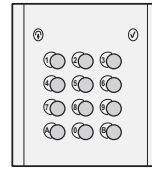

FC52PL
Tastiera per controllo accessi
Keypad for access control

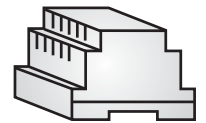

PRS210
Trasformatore
Transformer

Installazione

Installation

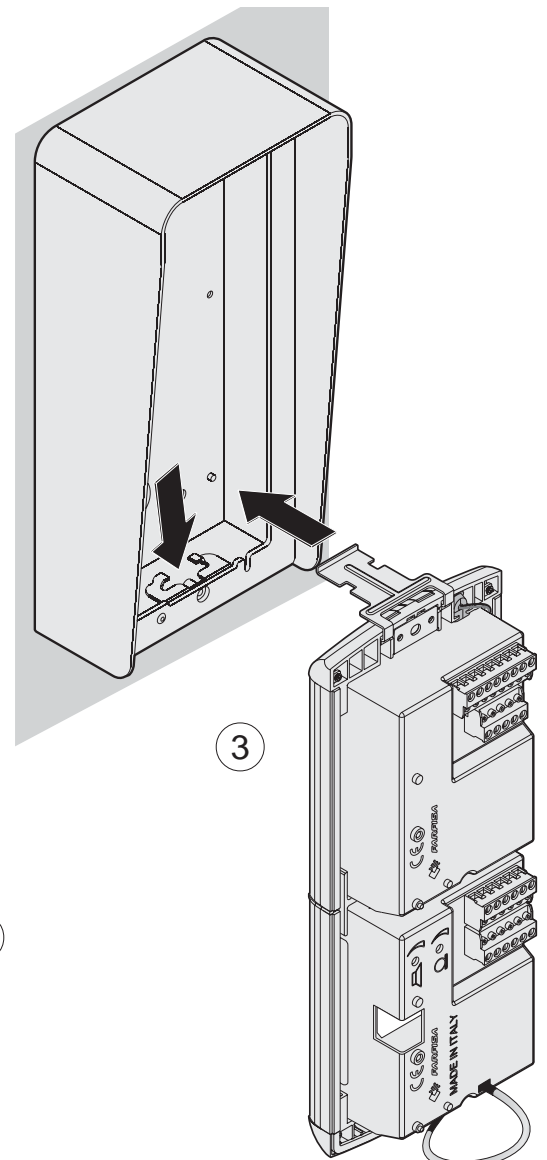
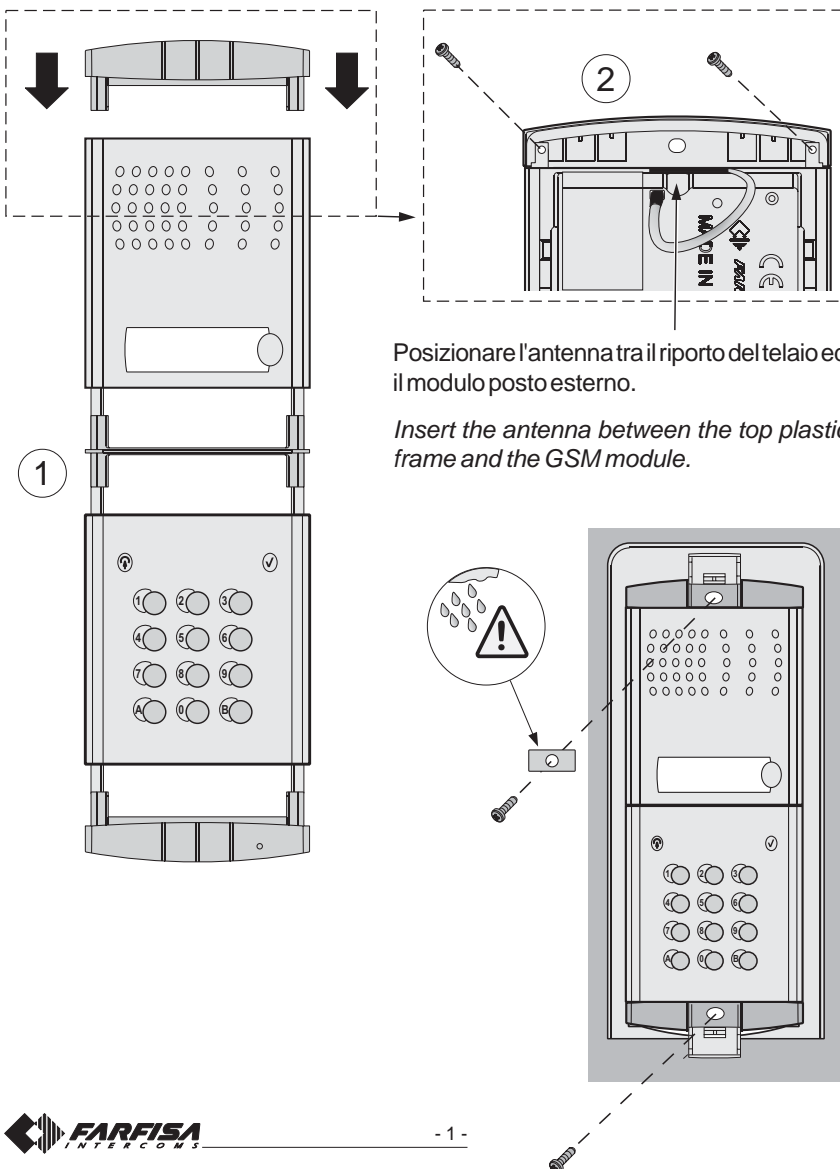

Schemi installativi di un impianto citofonico GSM

I 2 schemi seguenti permettono l'attivazione del cancello automatico e della serratura elettrica sia componendo il codice precedentemente programmato sulla tastiera FC52PL, sia utilizzando la funzione CLIP del posto esterno PL11G, sia componendo sul telefono il numero a 2 cifre di attivazione durante la conversazione con il posto esterno (vedere le istruzioni allegate ai prodotti).

1) Schema con azionamento in parallelo dei relè 1 e 2 della tastiera FC52PL con i relè 1 e 2 del posto esterno PL11G.

Attenzione. Con questo schema i relè 1 e 2 della tastiera FC52PL e del posto esterno PL11G devono essere programmati tutti allo stesso modo.

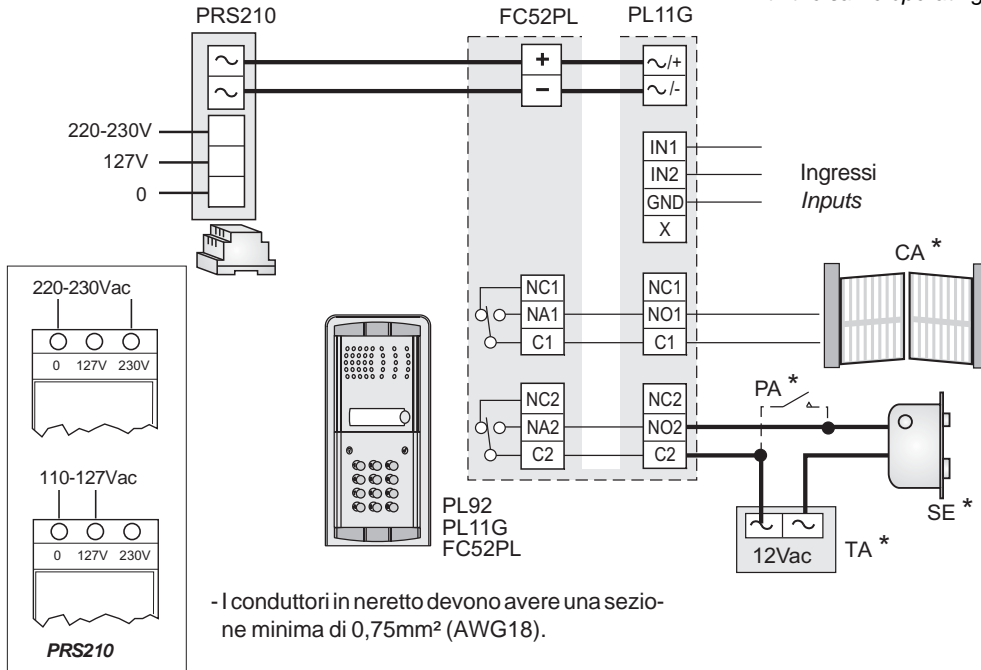

Installation diagram for a GSM intercom system

The two following diagrams show how to operate an automatic gate and an electrical lock release either entering a personal code on the Keypad FC52PL, or through the CLIP function of GSM module PL11G, or dialling, on your telephone, the 2 digit codes for the actuation of the two output relays during a conversation with the door station (for details see the enclosed technical manual of the products).

1) Diagram for parallel operations of relay 1 and 2 of keypad FC52PL with relays 1 and 2 of the door station PL11G.

Attention. The previous diagram requires that relays 1 and 2 of keypad FC52PL and those of the door station PL11G had been all programmed with the same operating mode.

- CA.** Cancelllo automatico.
Automatic gate.
- PA.** Pulsante apriporta (opzionale).
Door release push-button (optional).
- SE.** Serratura elettrica (12Vca-1A max.).
Electric door lock (12Vac-1A max).
- TA.** Trasformatore aggiuntivo da 12Vca e di potenza adeguata per l'azionamento della serratura elettrica (tipo PRS210).
Additional transformer from 12Vac and appropriate power to activate the electric door lock (type PRS210).

* Articoli non presenti nel kit.
Articles not included in the kit.

- The cables, which are heavily outlined, have a minimum section of 0.75mm² (AWG18).

2) Schema con azionamento diretto dei relè 1 e 2 del posto esterno PL11G.

I relè della tastiera FC52PL non comandano direttamente le serrature, ma esse sono attivate utilizzando gli ingressi del posto esterno PL11G.

Attenzione. Con questo schema occorre programmare correttamente i modi ed i tempi di attivazione degli ingressi e delle uscite del posto esterno PL11G.

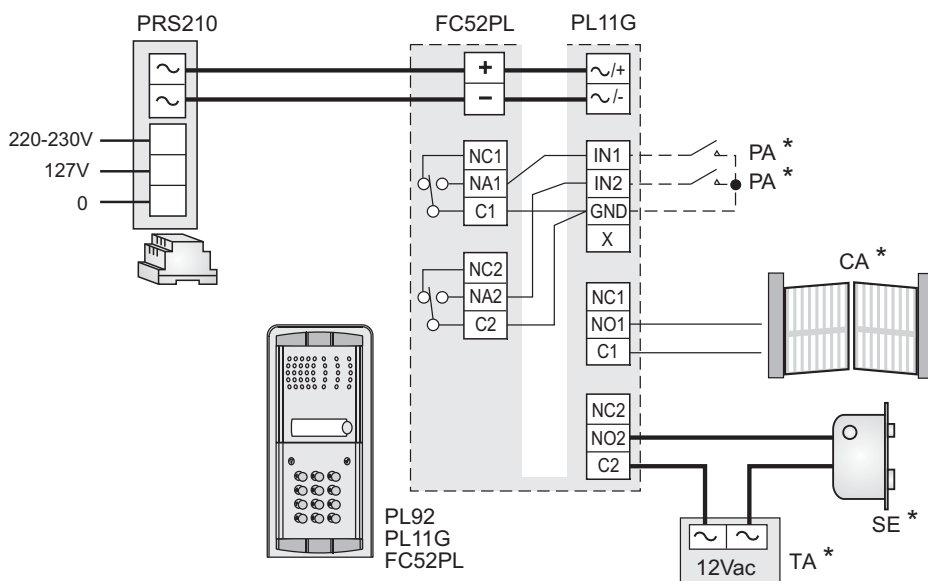

2) Diagram for direct operation of relays 1 and 2 of the door station PL11G.

Relays of keypad FC52PL do not drive directly the lock releases, but them are activated through the inputs of door station PL11G.

Attention. The previous diagram requires that operating modes and activation times of either inputs or outputs of door station PL11G had been all opportunely programmed.

IMPORTANTE

Al fine di ridurre i disturbi dovuti alla commutazione della serratura elettrica, è necessario collegare i transil (inclusi nell'articolo FC52PL) il più vicino possibile al carico.

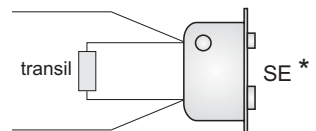

IMPORTANT

In order to reduce the noise due to the switching of the electric lock, it is necessary to connect the transil (included in the article FC52PL) as close as possible to the load.



Smaltire il dispositivo secondo quanto prescritto dalle norme per la tutela dell'ambiente.
Dispose of the device in accordance with environmental regulations.
Écouler le dispositif selon tout ce qu'a été prescrit par les règles pour la tutelle du milieu.
Eliminar el aparato según cuánto prescrito por las normas por la tutela del entorno.
Disponha do dispositivo conforme regulamentos ambientais.
Werden Sie das Gerät in Übereinstimmung mit Umweltregulierungen los.

La ACI Srl Farfisa Intercoms si riserva il diritto di modificare in qualsiasi momento i prodotti qui illustrati.
ACI Srl Farfisa Intercoms reserves the right to modify the products illustrated at any time.
La ACI Srl Farfisa Intercoms se réserve le droit de modifier à tous moments les produits illustrés.

ACI Srl Farfisa Intercoms se reserva el derecho de modificar en cualquier momento los productos ilustrados aquí.
E' riservata a ACI Srl Farfisa Intercoms o diritto de modificar a qualquer momento os produtos aqui ilustrados.
Änderungen vorbehalten.

ACI srl Farfisa Intercoms
Via E. Vanoni, 3 • 60027 Osimo (AN) • Italy
Tel: +39 071 7202038 (r.a.) • Fax: +39 071 7202037
e-mail: info@acifarfisa.it • www.acifarfisa.it

Cod. 52705050

FR KIT DE PORTIER AVEC CLAVIER POUR CONTRÔLE D'ACCÈS

ES KIT DE PORTERO CON TECLADO POR EL CONTROL DE LOS ACCESOS

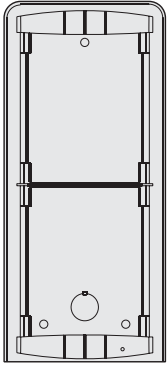

PL92
Visière antipluie avec cadres
Caja de superficie con soportes

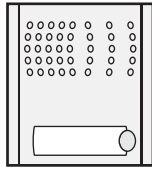

PL11G
Plaque de rue avec technologie GSM
Placa de calle con tecnología GSM

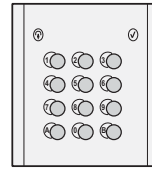

FC52PL
Clavier pour contrôle d'accès
Teclado por el control de los accesos

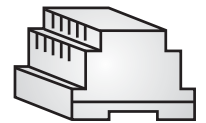

PRS210
Transformateur
Transformador

Installation

Instalación

